

□□□ **bill** □□□ □□ □□ □□ □□ □□ □□

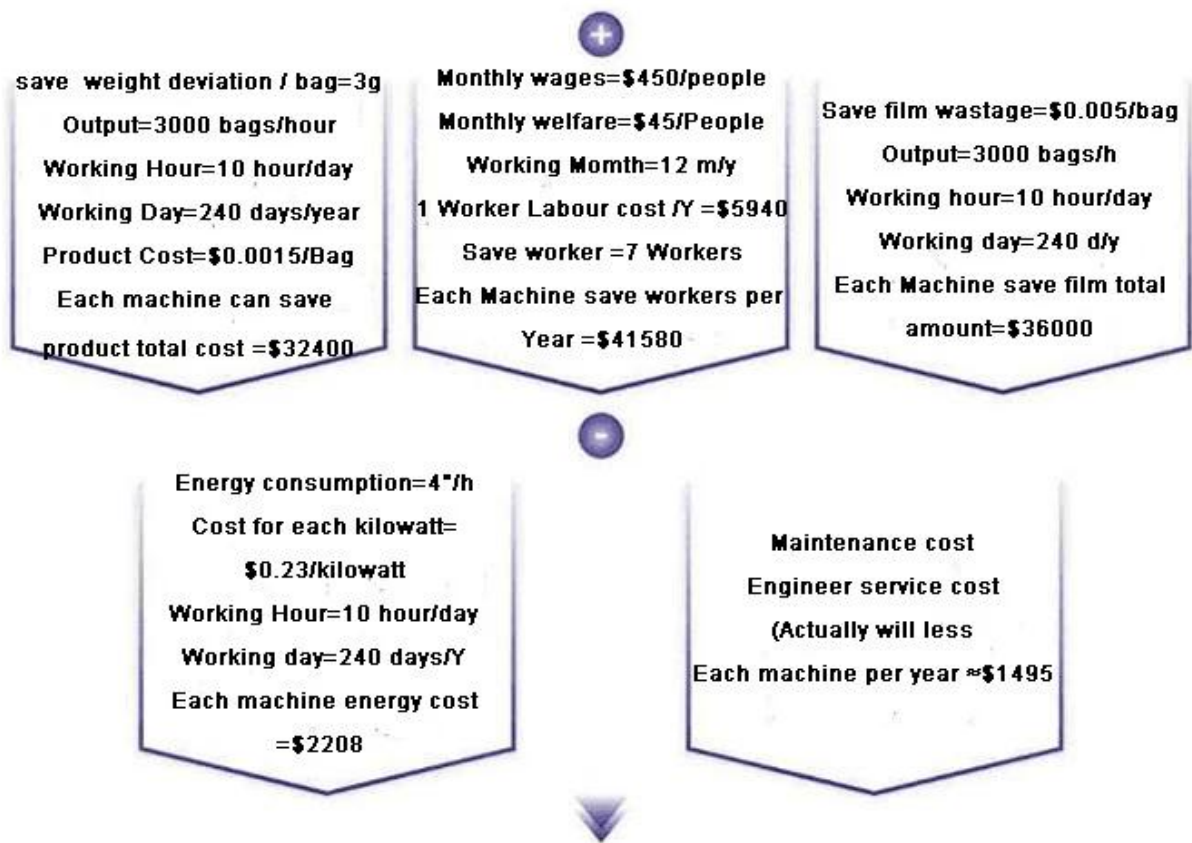

**Using our machine total cost around=\$106,277**

□□ □□ □ □□, □□□ □□□, □□ □□□ □□□ □□ □□ □ □□□ □□□ □□ □□□

1	□□□□ □□ □□□ □□ □□□ □□ □ □□□□.
2	□□ □□ □□ □ □□□ □□ □□□ □ □□□□ □□ □ □□□□.
3	□□□□ □□□ □□□.
4	□□ □□□□ □□□ □□□□ □□□ □□□ □□ □□□ □□ □□□.
5	100 □□□□□□ □□ □ □□ □□ □□□ □□□ □ □□□□.

6	□□ □□ □□ □ □ 15 □ □□.
7	□□ □□ □□□□ □□ □ □□□□.

□□ne □□



**Multi-mouth Feeder Weigher**

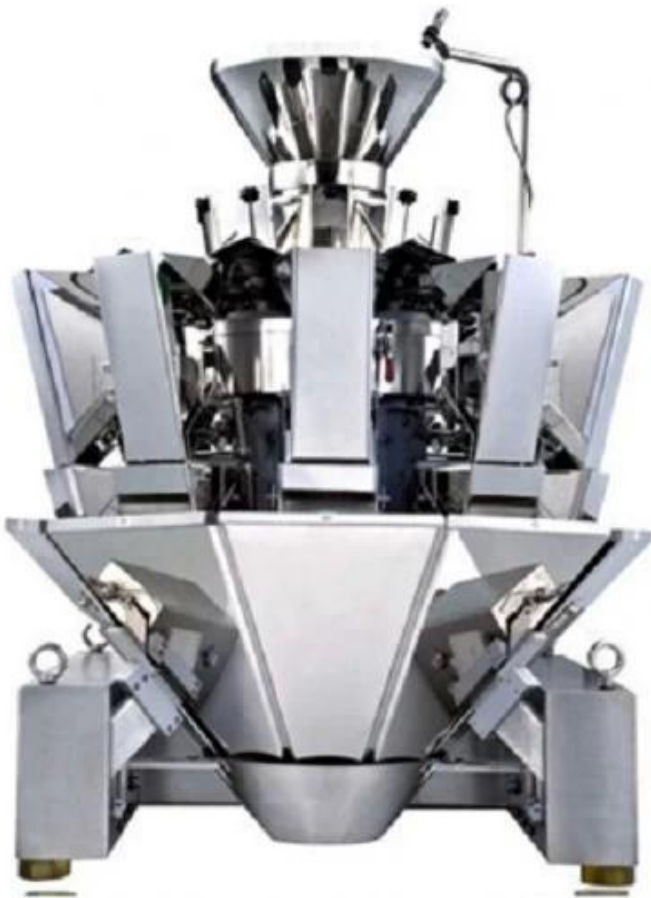
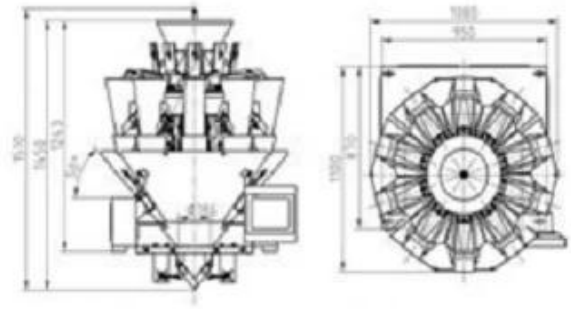

000 0 000 000 00 00 00 00 0 00 00 00  
 hg 00 00 0 000 00 00 00 000 00 0000. 00, 0 00 0 00, 0 0 0, 00 00, 00, 000000, 00 00,0 0, 00 0, 0 0  
 0, 00 00, 0, 00 00, samosa, 000 0, 00







1. 0 0 00 00 000 0000 00 0 0-00 00

00 00, 00 0 00.

2. 000 000 eu 0 0 0000 00 00.

3. 000, 000 000 00 0000 00 000 00 00 0 0 00 00 00 00, 00, 000, 000, 00, 0000, 00000, 00000, 00000 etc.

4. 00 00 0 000 0000 00 00, 00 00 000 000 000 00

00 0000 000 0 0 000 000 000 00.

000 **p**00 00





החברה מספקת שירותי אחר-המכירה, הכוללים ייעוץ טכני, תמיכה טכנית, אספקת חלקים, שירותי התקנה ושירותי תחזוקה. (החברה מספקת שירותי אחר-המכירה, הכוללים ייעוץ טכני, תמיכה טכנית, אספקת חלקים, שירותי התקנה ושירותי תחזוקה.)



# AFTER-SALES SERVICE

□□:

החברה מספקת שירותי אחר-המכירה, הכוללים ייעוץ טכני, תמיכה טכנית, אספקת חלקים, שירותי התקנה ושירותי תחזוקה. (dhl etc.)

# Machine Packing Process

10 Weighing Heand



Main Machine



Z Elevator



Wapping the Machine

And Put into Wooden Case



□□□ □ □□□ □□□ □□ □□ □□ □□ □□ □□