

CE certified doypack packaging machine Pecans nuts packaging machine

< INTRODUCE >

The "CE certified doypack packaging machine Pecans nuts packaging machine," Model DS-GDS300-08, is a cutting-edge packaging solution offered by Foshan DESSION Packaging Machinery Co., Ltd. This advanced machine is designed to efficiently package a wide range of products, including pecans nuts, in various pre-made bag formats such as flat bags, stand-up bags, zipper bags, handbags, and M bags. With its eight-station structure and state-of-the-art technology, it simplifies the packaging process, enhances productivity, and ensures precision and reliability. DESSION's commitment to quality is reflected in this machine, which complies with GMP standards and holds CE certification.

< APPLICATION SCENARIOS >



< MACHINE ADVANTAGES >

1. The whole machine has an eight-station structure and is centrally controlled by an industrial computer (based on the ethercat bus) and a large touch screen. The operation is simple and convenient;
2. Equipped with automatic fault tracking and alarm system, and real-time display of operating status;
3. Empty bag tracking and detection device, which can realize no sealing when the bag is not opened or unloaded, saving packaging materials;
4. The full servo control system is used for action execution, and the execution is reliable, fast, and accurate;
5. The whole machine design complies with GMP standards and has

passed CE certification.

[CONTACT NOW](#)



< MACHINE DETAIL MARKINGS >

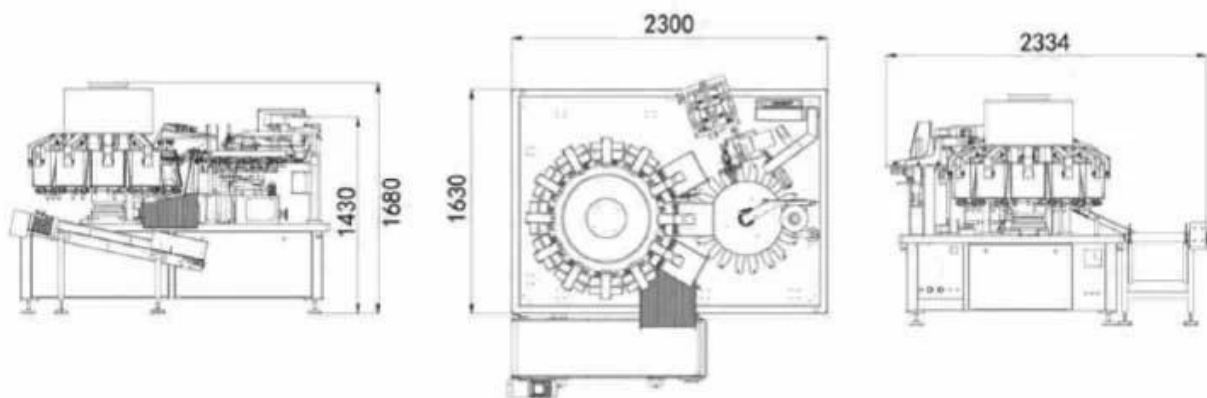

< DETAIL >







ELECTRONIC SCALE



Combination electronic scale with high precision and accurate measurement

A



VACUUM SUCTION BAG



The vacuum suction cup suckhagaically transports it to the work area

B



VACUUM AUTOMATIGBAG OPENING



The width can be adjusted freely
to suit the size of different prod-
ucts



WEIGHT SELECTION SCALE



Automatic product weighing,
smart and efficient



[CONTACT NOW](#)



COMPANY PROFILE



FOSHAN DESSION PACKAGING MACHINERY CO., LTD.

Foshan Dession Packaging Machinery Co., Ltd. is located in China Machinery Center, Nanhai District, Foshan city. Dession is a collection of research and development, manufacturing, sales and after-sales service in one of the high-tech enterprises. It has the self-import and export rights. DE newsletter focusing on production and research and development, all kinds of bag packaging machine, filling machine, and the research and development and manufacture of automatic packaging line with superior performance advanced technology, easy operation, easy maintenance, safe, durable widely used in puffed food, snack food, frozen food, agricultural and sideline products, medicine, chemical products and other fields to meet the needs of customers.



9000

Square Meters
of Factory Buildings

15 Years

Focus on
packaging machinery

**More
than 80**

Technicians
and employees

**More
than 100**

Packing
machine models

< WORKSHOP DIAGRAM DISPLAY >



**FILLING MACHINE
WORKSHOP**

**LARGE VERTICAL
WORKSHOP**

**PILLOW MACHINE
WORKSHOP**



**SMALL VERTICAL
WORKSHOP**

**CARTONING MACHINE
WORKSHOP**

**MULTI-TRAIN
WORKSHOP**

CONTACT NOW



< CERTIFICATE DISPLAY >

it owns more than 20 authorized intellectual property rights and has passed ISO9001 certification every year.



Certificate of Honor



Patent certificate

< CUSTOMER TESTIMONIALS >

True praise and good quality are all based on customer needs

Service praise

Great job done by Foshan Dession ... I want to thank you all for this nice experience ... the next to come is the best 🤗

Quality praise

Hi Christy

At the moment dont need help

we test it one time

it works

now waiting the bobbins

Quality praise

Ok. Thank you, we will inform you!!!

Thaaaaank you very much dear Alisa you are Super, perfect with your engineer 🙌🙌🙌🙌🙌🙌. Everything is ok.

77 roses for you from heart

Ok thanks. Am busy installing the last machine

2021

i did the installation today, perfect machine

Quality praise

12:23

Hesham 南非水烟机

So next ye 今天 visit

Okay good luck

All the best

Thank you

First you use the machine and any thing you need you can ask me

Thanks

Service praise

My pleasure , it's happy to get your good feedback on the machine

1 条未读信息

It's good And your service is excellent Your Boss must give increase

成 Neal 美国单工位预制袋混合沙

Quality praise

Hello Joe - the machine continues to run better every day. We're hoping that all the parts do not start to break with use.

If anything breaks (like the heating bar), can you send up replacement parts?

晚上11:42

EXHIBITIONS & CUSTOMER VISITS



International exhibition



Customer visit

CONTACT NOW



< OUR SERVICE >



Worry Free After Sale

Professional after-sales team with 10 years of experience

24-hour online after-sales

Professional technical team, on-site installation service

on-site debugging training



With a professional after-sales service team, we can provide you with satisfactory and technical service no matter which country you are in; Any videos of packing machine installation, adjusting, setting, and maintenance are available for any buyer; If you have any problem when using the machine and the videos can not help, our technician will video chat with you to fix your problem; (Notice: In order to save your cost, we offer various video chatting services for you, but if you insist on the service overseas, the travel expense and technician cost will paid by you.)

< OUR SHIPPING >



Upon receipt of payment , delivery date will be in 15-30 working days, By Air, by Sea or by Express (DHL etc)

FAQ

Q1. Are you a manufacturer?

A1: Yes, we are an experienced manufacturer with our own brand and production lines, welcome to visit our factory at your convenient time.

Q2. How about the quality of products?

A2: Our technicians and QC teams test the products one by one using aging lines, professional devices, and instruments to ensure the quality of all products.

Q3. How about the price?

A3: We are a manufacturer and always offer our customers the most competitive prices.

Q4. How to place an order?

A4: Contact with online service, or send an email to us directly, we will reply to you with the product price, specifications, packing, etc. soon.
Thank you.

Q5. May I send samples to you for testing?

A5: Yes! You are welcome to send us your products to test by our machine.

Q6. How long is your delivery time?

A6: Generally it is 5-10 days if the goods are in stock. or it is 15-30 days if the goods are not in stock.